

# OWNERS MANUAL



**CAUTION:** Risks of electrical shock — DO NOT OPEN



**CAUTION:** To reduce the risk of electric shock, do not remove cover. No user serviceable parts inside. Refer Servicing to qualified service personnel.



**CD MIX™**  
**7032**

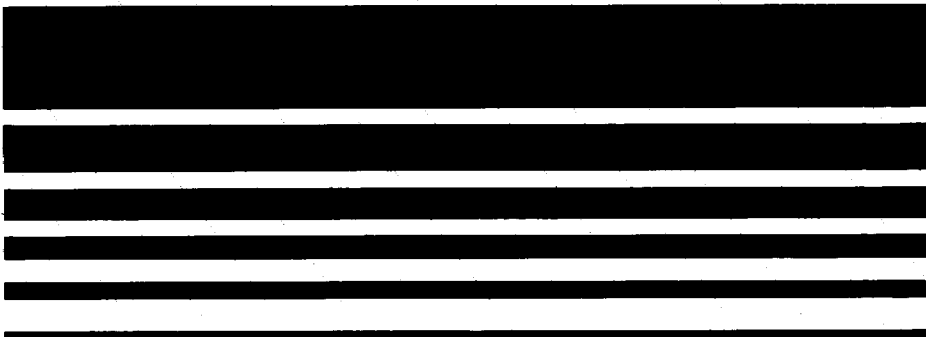

**WARNING: TO PREVENT ELECTRICAL SHOCK OR FIRE HAZARD, DO NOT EXPOSE THIS APPLIANCE TO RAIN OR MOISTURE. BEFORE USING THIS APPLIANCE, READ THE OPERATING GUIDE FOR FURTHER WARNINGS.**

## **CD MIX™ 7032**

Please read this entire manual before hooking this mixer into your audio system.

**CAUTION:** Do not use spray cleaner for any slide control as this will wash out vital lubricants and shorten component life.

## Parts Inventory

Thank you for purchasing the Peavey CD MIX 7032 professional DJ mixing unit. When used in accordance with this manual, your new DJ mixer will give years of good service.

In order to read this manual you will have already unpacked the unit.

You should have:

One mixer unit.

One 16VAC UL listed wall-mount power supply unit.

Please retain the packing material for future use.

## Features:

- Rapid, positive CD/phono toggle switches on three music inputs
- Channel-assignable Crossfade facility
- Three Phono/CD and three Line level inputs; a total of six music inputs
- 3-band graphic EQ  $\pm 12$  dB on each band; 30 mm slide pots fitted with center-detent for easy zeroing of EQ
- Front-panel-mounted Low-Z Mic input
- Selectable headphone cueing for each music channel
- Manual push-to-talk voice-over button
- Cueing selector to listen to stereo program output, stereo channel cueing, or mono channel cue in right earcup and program output in left earcup
- Built-in gooseneck XLR light socket
- 45 mm heavy-duty crossfade slider
- Mic bass cut switch
- Power on/off switch with LED indicator
- 45 mm headphone volume slider
- High slew-rate super low-noise op amps used throughout the entire mixer circuitry
- 60 mm high-quality Alps slide faders on all channels and master level control
- Available in 115V 60 Hz and 220-240V 50 Hz versions
- Extra program output provided for monitoring or lighting equipment

## General Description:

The CD MIX™ 7032 multi-media entertainment mixer is a brand new addition to Peavey's line of premium quality DJ equipment.

It is an all-American-made, high-quality, rugged, professional DJ mixer.

DJs, rap recording artists, and specialist DJ equipment dealers were closely involved in active consultancy during and throughout each design stage.

Housed in a 5-1/4" x 19" super slim-line (only 1-3/4" deep) rugged steel chassis, the CD MIX 7032 boasts a truly remarkable array of much-preferred DJ features like: three individual music channels; six music inputs, three of these inputs being individually switchable to phono or CD; fully assignable crossfade; three-band audio EQ; and built-in gooseneck XLR light socket. All slider potentiometers and switches are studio-quality Alps components.

The low-impedance, phantom-powered, front-panel-mounted microphone input delivers fast, positive connect and disconnect facility for the DJ's mic. Many other DJ mixers have the mic socket mounted on the rear of the mixer chassis so the mixer has to be physically lifted out of the console to work with the mic connection.

Because CDs are playing a much larger part as the preferred DJ music medium and vinyl is becoming very difficult to obtain, each phono input on this DJ mixer has an individual slide switch that changes the input from vinyl to CD (or back again) quickly and easily. So, as vinyl becomes even more scarce, every Phono (record deck) input may also be used for CD players. This method of vinyl/CD selection is unique to the Peavey line of DJ mixers.

## FRONT PANEL

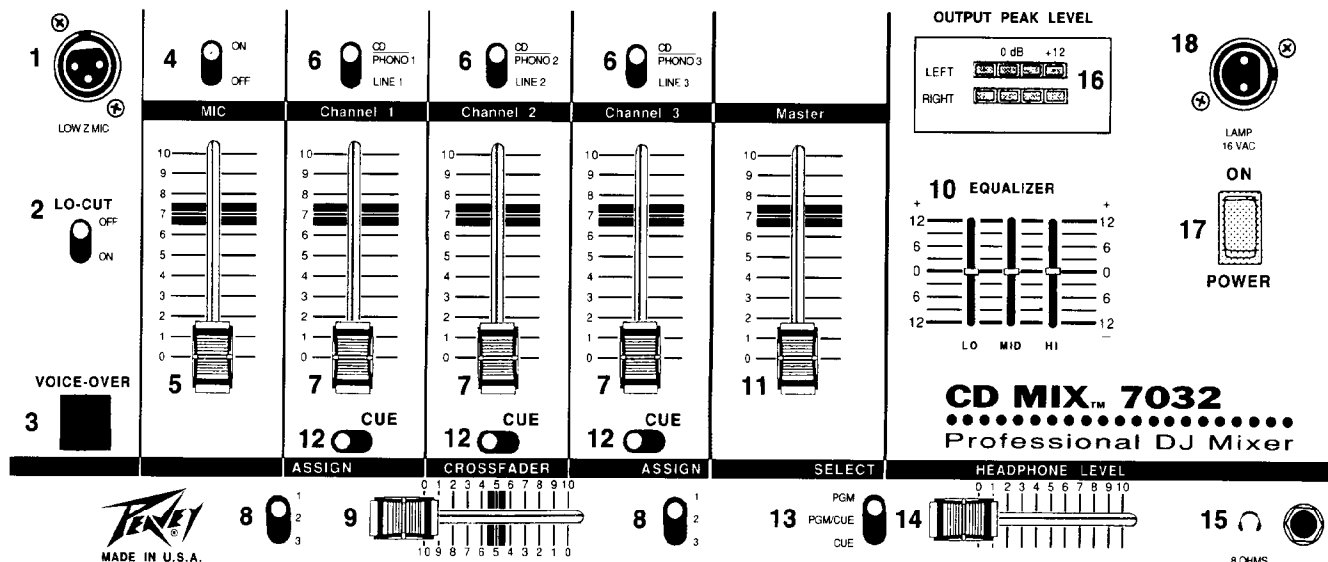

### Mic Channel:

**(1) Balanced Low Z Microphone Input** - For use with low impedance microphones or low level sources equipped with an XLR connector.

**(2) Lo-Cut Switch:** Removes low frequencies from the microphone response when in the ON position, thus making speech more easily understood when the Equalizer is set for high-bass-boost.

**(3) Voice-Over Button:** When pressed, this drops the music level to enable the DJ to make himself heard.

**(4) DJ Mic On/Off Switch:** The DJ mic is "live" when the switch is in the ON position.

**(5) Microphone Level Slider:** A mono slider that determines the output level of the microphone channel.

### Music Channels:

Note: Channels 1, 2, and 3 functions are identical.

**(6) Phono/CD Or Line Selector Switch:** Allows selection of phono/CD (L and R) or line (L and R) inputs. The "Line" position of this switch selects the line input, and the "CD-Phono" position selects the CD/phono input.

**(7) Channel Level Slider:** A stereo slider that determines the output level of the channel.

**(8) Crossfade Assign Switches:** The left-hand switch assigns channel 1, 2, or 3 to the left-hand side of the crossfader. The right-hand switch assigns channel 1, 2, or 3 to the right-hand side of the crossfader.

**(9) Crossfade Slider:** A stereo slider which delivers crossfade capability between channels one, two, or three according to the position of the two crossfade assign switches.

Full left positioning of this stereo slide control places the output on channel 1,2, or 3 depending on the position of the left-hand crossfade switch.

Full right positioning of this control places the output on channel 1,2, or 3 depending on the position of the left-hand crossfade switch.

The midpoint of slider travel creates a mixed output from both of the assigned channels.

Blending and crossfading between all channels is accessible by assigning channels 1,2, or 3 for left and right positioning of the crossfade slider.

For example:

Left-hand ASSIGN switch set to channel #3 will access channel 3 when the crossfade slider is in the left-hand position.

Right-hand ASSIGN switch set to channel #2 will access channel 2 when the crossfade slider is in the right-hand position.

**NOTE:** It is useful to remember that when the crossfade slider is set to its center (number 5) position both channels assigned to the left and right-hand crossfade positions will be at equal levels. You may now simply use the channel level controls to crossfade between the two assigned channels and ignore the crossfade, leaving it set in the center position.

**(10) 3-Band EQ:** Used to boost or cut three selected frequency bands (LO, MID, HI) according to the placement of the three slide potentiometers.

**(11) Program MASTER Level:** A stereo slider that determines the overall program level from channels 1, 2, 3, and the microphone channel.

#### **Headphone/Cue system:**

**(12) CUE Switches:** When placed in the right-hand position, these switches route the channel signal to the cue system. When placed in the left-hand position, these switches route the channel signal out of the cue system.

**(13) Cue Select Switch:** The PGM position of this switch delivers headphone monitoring of all stereo program material present at the outputs. The PGM/CUE position delivers monitoring of the program (output) material to the left earcup of the headphones. Material present on the cue bus (see CUE switches 12) may be heard in the right earcup of the headphones. The CUE position delivers cue material, in stereo, to the headphones' left and right earcups.

**(14) Headphone Level Slider:** Sets sound levels available at the Headphone Jack (15)

**(15) Headphone Jack:** Stereo headphones plugged in at this point will allow monitoring of program material or cueing system. **Note:** Do not use mono headphones with this system.

#### **Crossfader:**

**(16) LED Arrays (Left And Right):** Two calibrated LED arrays are provided to visually indicate program output levels.

**(17) Power Switch:** Depress to the "On" position to turn on.

**(18) Lamp:** A 2-pin XLR jack is provided for connecting an optional gooseneck mixer lamp for illumination in adverse lighting conditions.

## REAR PANEL

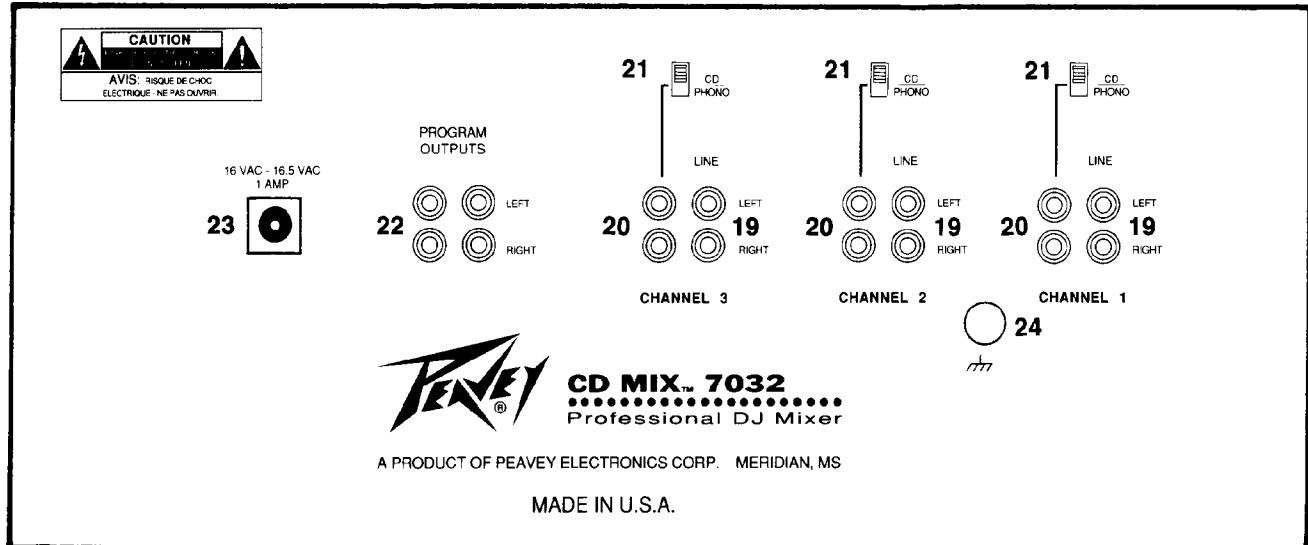

### Channel inputs:

**(19) Line Inputs:** Left and right inputs are provided for “line level” signals from tape decks, CDs, or other sources. See also (6) Phono/Line Selector Switch.

**(20) CD/Phono Inputs:** Left and right inputs are provided for output from turntables or CDs, depending on position of the CD/Phono switch (21) on each channel. See also (6) Phono/Line Selector Switch.

**(21) CD/Phono Switch:** Selects the CD/Phono inputs to accept input from either a magnetic phono cartridge (Phono [switch down] position) or a CD or other line source (CD [switch up] position).

### Program outputs:

**(22) Program Outputs:** Two main output left and right jacks are provided for the main (program) output. The outputs at this point should be patched out to the stereo power amplifiers driving the main speaker system. The second pair of outputs may be used to drive lighting controllers or for tape recording.

### Power input:

**(23) AC Input:** External 16.5 volt, 1 amp power supply should be plugged in at this point.

Plug the power supply provided with your CD MIX 7032 into a main a. c. wall power receptacle. Plug the small jack at the end of the power supply lead into the 16V AC socket on the rear of the unit (23).

**CAUTION:** Use only the power supply that is provided with this product. If the original power supply must be replaced, consult your dealer or the factory for assistance in obtaining the correct replacement. Failure to use the correct power supply could result in fire or shock hazard, extensive circuit damage, decreased performance, or non-operation.

**(24) Chassis Ground Lug:** Grounds from other pieces of equipment should be connected at this point to minimize ground loop possibilities between power amps, outboard signal processing units, turntables, etc.

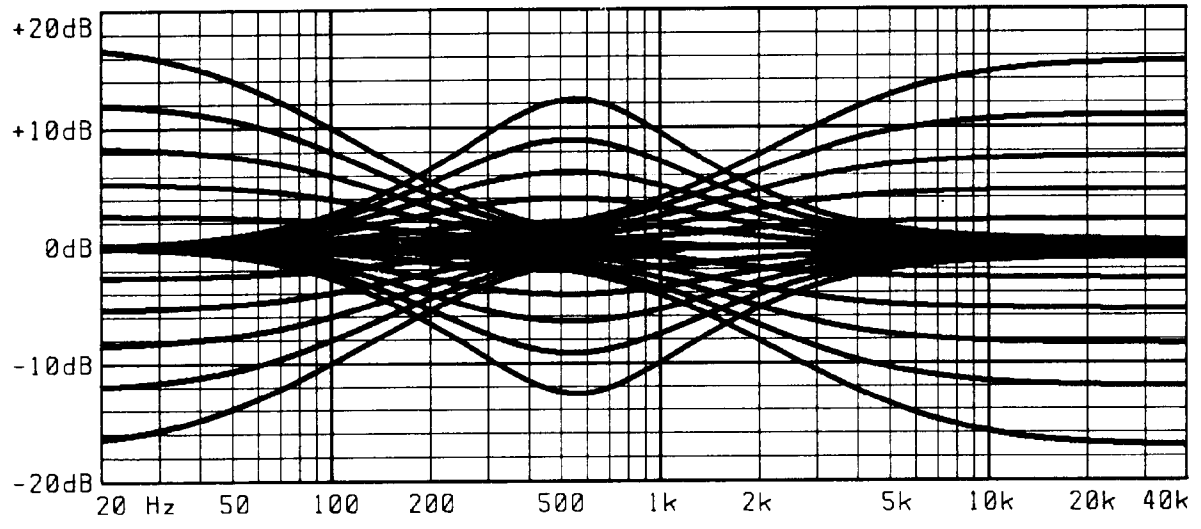
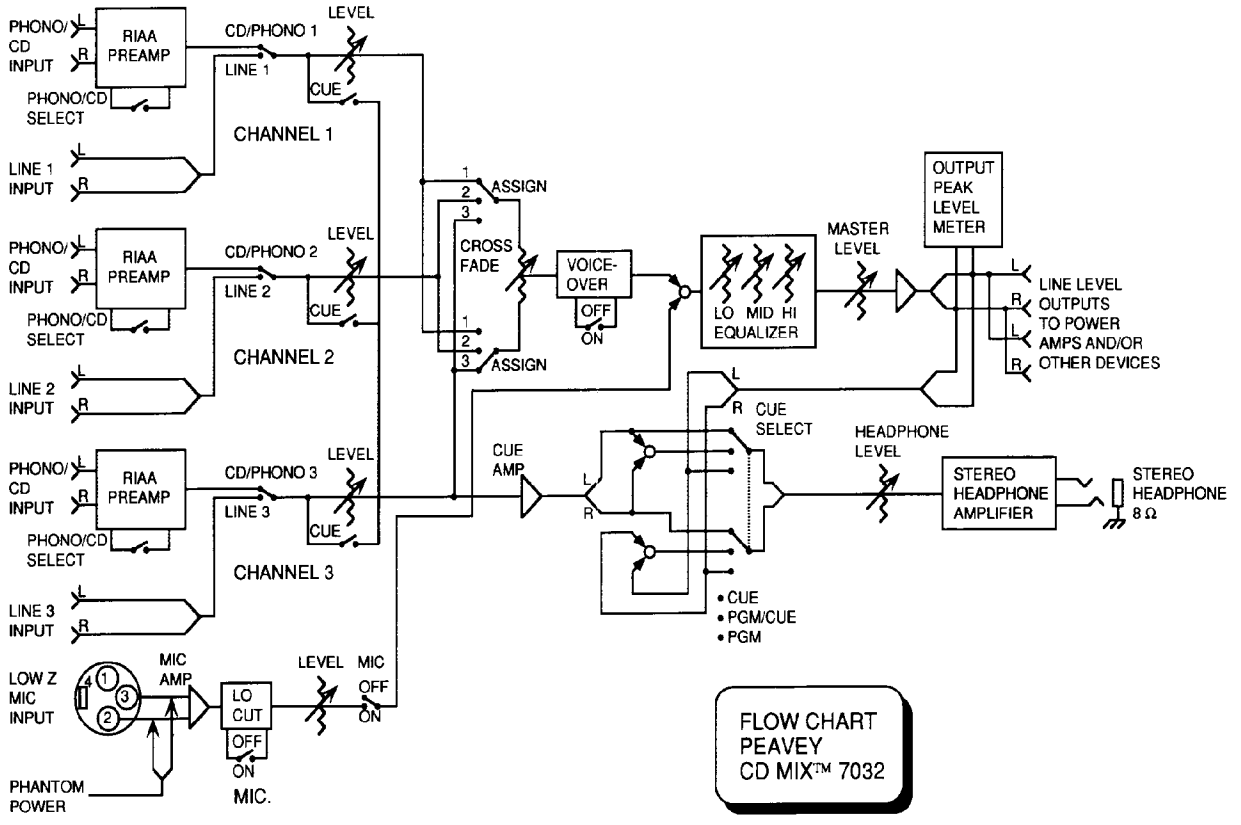

**EQ Frequency and Gain Characteristics**

## **CD MIX™ 7032 SPECIFICATIONS**

### **SUMMARY OF FUNCTIONS:**

6 stereo inputs - 3 CD/phono and 3 line  
3-way assignable crossfade  
1 microphone mixing bus with manual music voice-over switch  
5-segment LED ladders  
Switchable stereo headphone jack  
15V phantom power for electret mics  
3-band program EQ  $\pm 12$  dB  
45 mm stereo crossfade slider  
One 12V AC mixer lamp socket

### **CHANNEL 1-3 FUNCTIONS (Each Channel):**

Stereo (RIAA) phono input switchable to CD  
Stereo line input  
CD/phono selector switch  
Stereo selector switch for line input or CD/phono input  
60 mm stereo level slider

### **MICROPHONE CHANNEL FUNCTIONS:**

Low Z balanced microphone input with phantom power  
Lo-cut switch  
Voice-over button  
Mic on/off switch  
60 mm stereo level slider

### **MASTER SECTION:**

3-band graphic equalizer  
Stereo 5-segment LED display  
60 mm stereo program level slider

### **CD/PHONO INPUTS:**

Phono position:

Input Sensitivity: -50 dB (3 mV)  
Input Impedance: 47 K ohms  
Max Input Level @ 1 kHz: -20 dBV (100 mV)

CD position:

Input Sensitivity: -10 dB (.316 volts)  
Input Impedance: 47 K ohms  
Max Input Level: +18 dBV (8 volts)

LINE INPUTS:

Input Sensitivity: -10 dB (.316 volts)  
Input Impedance: 8.3 K ohms  
Max Input Level: +18 dBV (8 volts)



**MICROPHONE INPUT (LOW-Z):**

Input Sensitivity: -70 dB (.3 mV)  
Input Impedance: 3 K ohms  
Max Input Level: +6 dBV (2 volts)

**MICROPHONE TALKOVER:**

Attenuation (voice-over switch enabled): 12 dB

**FREQUENCY RESPONSE:**

Phono Inputs (RIAA): +0/-3 dB (20 Hz to 20 kHz)  
Line Inputs: +0/-3 dB (20 Hz to 20 kHz)  
Headphone: +0/-3 dB (40 Hz to 20 kHz)

**SIGNAL-TO-NOISE RATIOS:**

Phono: > 70 dB  
Line: > 90 dB

**EQUALIZATION:**

Low:  $\pm 12$  dB at 50 Hz  
Mid:  $\pm 12$  dB at 600 Hz  
Hi:  $\pm 12$  dB at 10 kHz

**MICROPHONE EQ:**

Low-cut filter: -3 dB at 300 Hz

**MAX OUTPUT LEVEL:**

+ 18 dBV (8 volts)

**POWER REQUIREMENTS:**

16.5V AC, 1000 ma external power supply

**Installing the unit:**

This mixer may be mounted in a standard 19" equipment rack using 19" rack-mounting screws and washers (Peavey accessory part #5003), or may be built into a console's surface by cutting a hole 16.75" x 7.00" into the console's surface and using screws to secure the unit. See diagram below for dimensions.

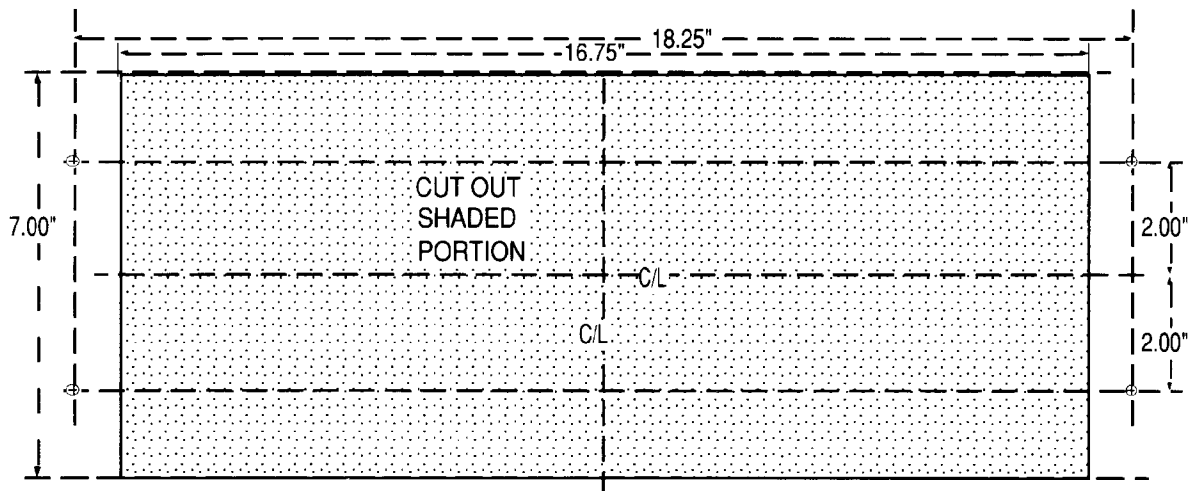

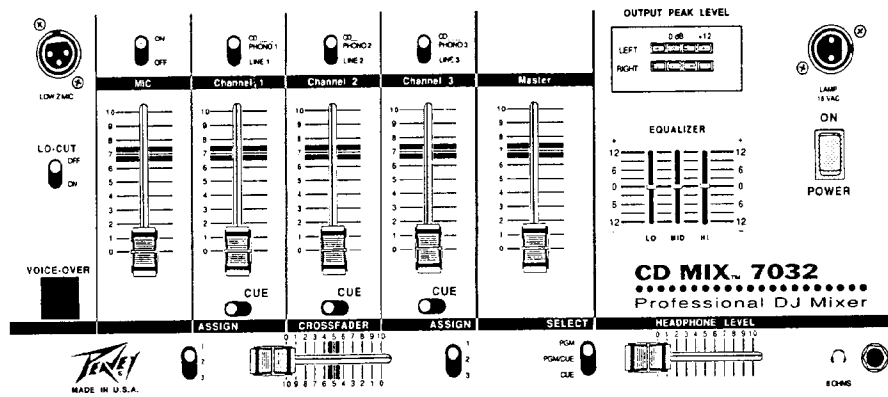
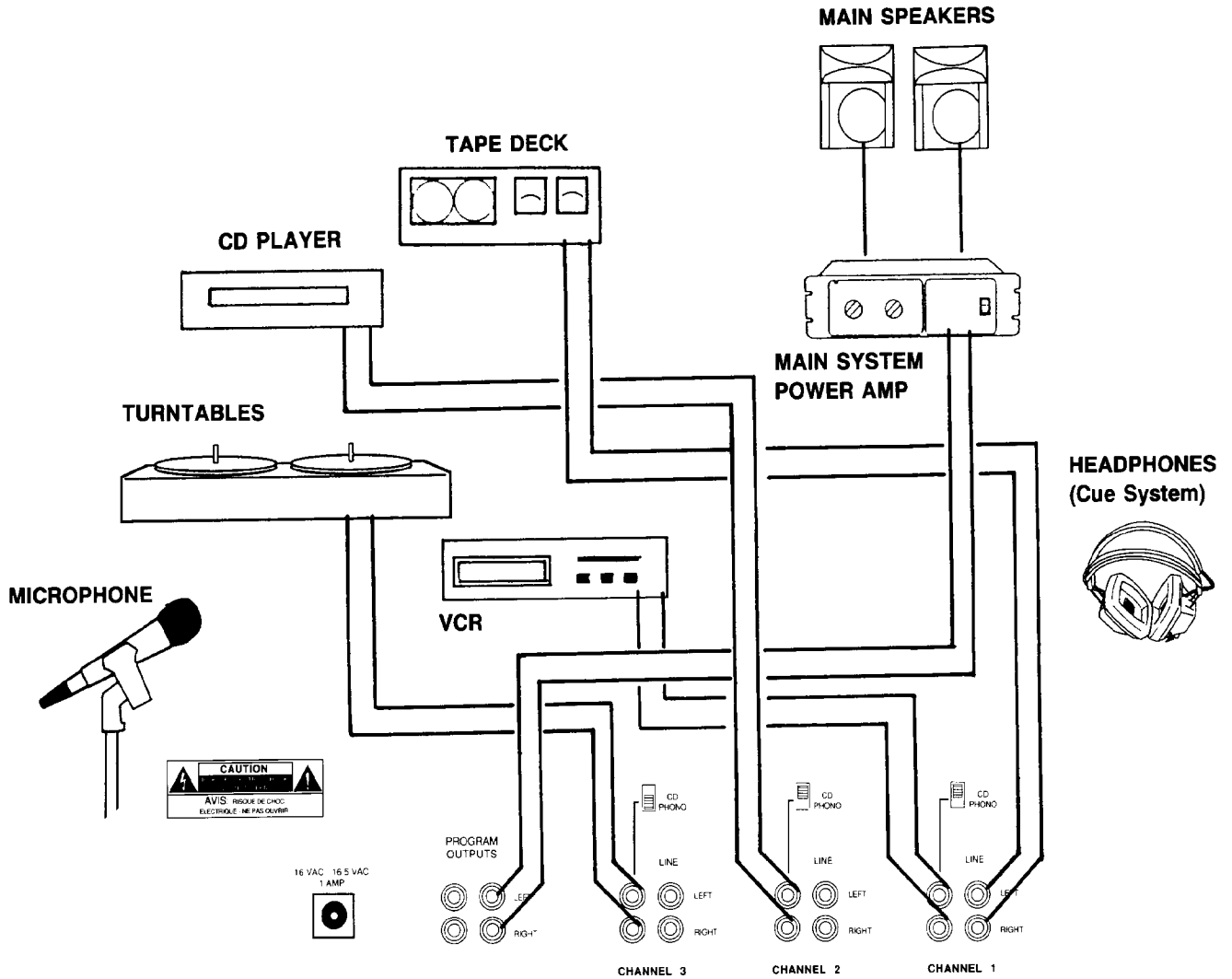

**THIS LIMITED WARRANTY VALID ONLY WHEN PURCHASED AND REGISTERED IN THE UNITED STATES OR CANADA. ALL EXPORTED PRODUCTS ARE SUBJECT TO WARRANTY AND SERVICES TO BE SPECIFIED AND PROVIDED BY THE AUTHORIZED DISTRIBUTOR FOR EACH COUNTRY.**

**Ces clauses de garantie ne sont valables qu'aux Etats-Unis et au Canada. Dans tous les autres pays, les clauses de garantie et de maintenance sont fixées par le distributeur national et assurées par lui selon la législation en vigueur.**

**Diese Garantie ist nur in den USA und Kanada gültig. Alle Export-Produkte sind der Garantie und dem Service des Importeurs des jeweiligen Landes unterworfen.**

**Esta garantía es válida solamente cuando el producto es comprado en E.U. continentales o en Canada. Todos los productos que sean comprados en el extranjero, están sujetos a las garantías y servicio que cada distribuidor autorizado determine y ofrezca en los diferentes países.**

#### **ONE-YEAR LIMITED WARRANTY/REMEDY**

PEAVEY ELECTRONICS CORPORATION ("PEAVEY") warrants this product, EXCEPT for covers, footswitches, patchcords, tubes and meters, to be free from defects in material and workmanship for a period of one (1) year from date of purchase, PROVIDED, however that this limited warranty is extended only to the original retail purchaser and is subject to the conditions, exclusions and limitations hereinafter set forth:

#### **PEAVEY 90-DAY LIMITED WARRANTY ON TUBES AND METERS**

If this product contains tubes or meters, Peavey warrants the tubes or meters contained in the product to be free from defects in material and workmanship for a period of ninety (90) days from date of purchase; PROVIDED, however, that this limited warranty is extended only to the original retail purchaser and is also subject to the conditions, exclusions and limitations hereinafter set forth.

#### **CONDITIONS, EXCLUSIONS AND LIMITATIONS OF LIMITED WARRANTIES**

These limited warranties shall be void and of no effect if:

- a. The first purchase of the product is for the purpose of resale; or
- b. The original retail purchase is not made from an AUTHORIZED PEAVEY DEALER; or
- c. The product has been damaged by accident or unreasonable use, neglect, improper service or maintenance, or other causes not arising out of defects in material or workmanship; or
- d. The serial number affixed to the product is altered, defaced or removed.

In the event of a defect in material and/or workmanship covered by this limited warranty, Peavey will:

- a. In the case of tubes or meters, replace the defective component without charge;
  - b. In other covered cases (i.e., cases involving anything other than covers, footswitches, patchcords, tubes or meters), repair the defect in material or workmanship or replace the product, at Peavey's option;
- and provided, however, that, in any case, all costs of shipping, if necessary, are paid by you, the purchaser.

THE WARRANTY REGISTRATION CARD SHOULD BE ACCURATELY COMPLETED AND MAILED TO AND RECEIVED BY PEAVEY WITHIN FOURTEEN (14) DAYS FROM THE DATE OF YOUR PURCHASE.

In order to obtain service under these warranties, you must:

- a. Bring the defective item to any AUTHORIZED PEAVEY DEALER or AUTHORIZED PEAVEY SERVICE CENTER and present therewith the ORIGINAL PROOF OF PURCHASE supplied to you by the AUTHORIZED PEAVEY DEALER in connection with your purchase from him of this product.

If the DEALER or SERVICE CENTER is unable to provide the necessary warranty service you will be directed to the nearest other PEAVEY AUTHORIZED DEALER or AUTHORIZED PEAVEY SERVICE CENTER which can provide such service.

**OR**

- b. Ship the defective item, prepaid, to:

PEAVEY ELECTRONICS CORPORATION  
International Service Center  
Highway 80 East  
MERIDIAN, MS 39301

including therewith a complete, detailed description of the problem, together with a legible copy of the original PROOF OF PURCHASE and a complete return address. Upon Peavey's receipt of these items:

If the defect is remedial under these limited warranties and the other terms and conditions expressed herein have been complied with, Peavey will provide the necessary warranty service to repair or replace the product and will return it, FREIGHT COLLECT, to you, the purchaser.

Peavey's liability to the purchaser for damages from any cause whatsoever and regardless of the form of action, including negligence, is limited to the actual damages up to the greater of \$500.00 or an amount equal to the purchase price of the product that caused the damage or that is the subject of or is directly related to the cause of action. Such purchase price will be that in effect for the specific product when the cause of action arose. This limitation of liability will not apply to claims for personal injury or damage to real property or tangible personal property allegedly caused by Peavey's negligence. Peavey does not assume liability for personal injury or property damage arising out of or caused by a non-Peavey alteration or attachment, nor does Peavey assume any responsibility for damage to interconnected non-Peavey equipment that may result from the normal functioning and maintenance of the Peavey equipment.

UNDER NO CIRCUMSTANCES WILL PEAVEY BE LIABLE FOR ANY LOST PROFITS, LOST SAVINGS, ANY INCIDENTAL DAMAGES OR ANY CONSEQUENTIAL DAMAGES ARISING OUT OF THE USE OR INABILITY TO USE THE PRODUCT, EVEN IF PEAVEY HAS BEEN ADVISED OF THE POSSIBILITY OF SUCH DAMAGES.

THESE LIMITED WARRANTIES ARE IN LIEU OF ANY AND ALL WARRANTIES, EXPRESS OR IMPLIED, INCLUDING, BUT NOT LIMITED TO, THE IMPLIED WARRANTIES OF MERCHANTABILITY AND FITNESS FOR A PARTICULAR USE; PROVIDED, HOWEVER, THAT IF THE OTHER TERMS AND CONDITIONS NECESSARY TO THE EXISTENCE OF THE EXPRESS, LIMITED WARRANTIES, AS HEREINABOVE STATED, HAVE BEEN COMPLIED WITH, IMPLIED WARRANTIES ARE NOT DISCLAIMED DURING THE APPLICABLE ONE-YEAR OR NINETY-DAY PERIOD FROM DATE OF PURCHASE OF THIS PRODUCT.

SOME STATES DO NOT ALLOW LIMITATION ON HOW LONG AN IMPLIED WARRANTY LASTS, OR THE EXCLUSION OR LIMITATION OF INCIDENTAL OR CONSEQUENTIAL DAMAGES, SO THE ABOVE LIMITATIONS OR EXCLUSIONS MAY NOT APPLY TO YOU. THESE LIMITED WARRANTIES GIVE YOU SPECIFIC LEGAL RIGHTS, AND YOU MAY ALSO HAVE OTHER RIGHTS WHICH MAY VARY FROM STATE TO STATE.

THESE LIMITED WARRANTIES ARE THE ONLY EXPRESS WARRANTIES ON THIS PRODUCT, AND NO OTHER STATEMENT, REPRESENTATION, WARRANTY OR AGREEMENT BY ANY PERSON SHALL BE VALID OR BINDING UPON PEAVEY.

In the event of any modification or disclaimer of express or implied warranties, or any limitation of remedies, contained herein conflicts with applicable law, then such modification, disclaimer or limitation, as the case may be, shall be deemed to be modified to the extent necessary to comply with such law.

Your remedies for breach of these warranties are limited to those remedies provided herein and Peavey Electronics Corporation gives this limited warranty only with respect to equipment purchased in the United States of America.

#### **INSTRUCTIONS — WARRANTY REGISTRATION CARD**

1. Mail the completed WARRANTY REGISTRATION CARD to:

PEAVEY ELECTRONICS CORPORATION  
POST OFFICE BOX 2898  
MERIDIAN, MISSISSIPPI 39302-2898

- a. Keep the PROOF OF PURCHASE. In the event warranty service is required during the warranty period, you will need this document. **There will be no identification card issued by Peavey Electronics Corporation.**
2. IMPORTANCE OF WARRANTY REGISTRATION CARDS AND NOTIFICATION OF CHANGES OF ADDRESS:
  - a. Completion and mailing of WARRANTY REGISTRATION CARDS — Should notification become necessary for any condition that may require correction, the REGISTRATION CARD will help ensure that you are contacted and properly notified.
  - b. Notice of address changes — If you move from the address shown on the WARRANTY REGISTRATION CARD, you should notify Peavey of the change of address so as to facilitate your receipt of any bulletins or other forms of notification which may become necessary in connection with any condition that may require dissemination of information or correction.
3. You may contact Peavey directly by telephoning (601) 483-5365.
4. Please have the Peavey product name and serial number available when communicating with Peavey Customer Service.

**DANGER**

EXPOSURE TO EXTREMELY HIGH NOISE LEVELS MAY CAUSE A PERMANENT HEARING LOSS. INDIVIDUALS VARY CONSIDERABLY IN SUSCEPTIBILITY TO NOISE INDUCED HEARING LOSS, BUT NEARLY EVERYONE WILL LOSE SOME HEARING IF EXPOSED TO SUFFICIENTLY INTENSE NOISE FOR A SUFFICIENT TIME. THE U.S. GOVERNMENT'S OCCUPATIONAL SAFETY AND HEALTH ADMINISTRATION (OSHA) HAS SPECIFIED THE FOLLOWING PERMISSIBLE NOISE LEVEL EXPOSURES:

DURATION PER DAY IN HOURS	SOUND LEVEL dBA, SLOW RESPONSE
8	90
6	92
4	95
3	97
2	100
1 1/2	102
1	105
1/2	110
1/4 or less	115

ACCORDING TO OSHA, ANY EXPOSURE IN EXCESS OF THE ABOVE PERMISSIBLE LIMITS COULD RESULT IN SOME HEARING LOSS. IF EAR PLUGS OR PROTECTORS IN THE EAR CANALS OR OVER THE EARS MUST BE WORN WHEN OPERATING THIS AMPLIFICATION SYSTEM IN ORDER TO PREVENT A PERMANENT HEARING LOSS. IF EXPOSURE IS IN EXCESS OF THE LIMITS AS SET FORTH ABOVE, TO INSURE AGAINST POTENTIALLY DANGEROUS EXPOSURE TO HIGH SOUND PRESSURE LEVELS, IT IS RECOMMENDED THAT ALL PERSONS EXPOSED TO EQUIPMENT CAPABLE OF PRODUCING HIGH SOUND PRESSURE LEVELS SUCH AS THIS AMPLIFICATION SYSTEM BE PROTECTED BY HEARING PROTECTORS WHILE THIS UNIT IS IN OPERATION.

**CAUTION**

THIS MIXING CONSOLE EFFECTS DEVICE/PREAMP HAS BEEN DESIGNED AND CONSTRUCTED TO PROVIDE ADEQUATE SIGNAL (VOLTAGE) FOR PLAYING MODERN MUSIC. IMPROPER USE OF THE GAIN/EQUALIZER CONTROLS AND/OR IMPROPER USE OF INTERNAL/EXTERNAL BUSES MAY CREATE CLIPPING (SQUARE WAVES) AND POSSIBLY CAUSE SUBSEQUENT DAMAGE TO THE LOUDSPEAKER SYSTEMS. EXTENDED OPERATION OF THE GAIN/EQUALIZATION CONTROLS IN THEIR MAXIMUM POSITIONS IS THEREFORE NOT RECOMMENDED. PLEASE BE AWARE THAT MAXIMUM POWER CAN BE OBTAINED WITH VERY LOW SETTINGS OF THE GAIN/EQUALIZATION CONTROLS IF THE INPUT SIGNAL IS VERY STRONG.

IT IS COMMON PRACTICE AMONG USERS OF SOUND REINFORCEMENT EQUIPMENT TO IDENTIFY THE INDIVIDUAL CHANNELS WITH A STRIP OF TAPE PLACED ABOVE OR BELOW THE ROW OF VOLUME FADERS. MANY TYPES OR BRANDS OF TAPE HAVE A VERY STRONG ADHESIVE WHICH CAN INHIBIT THE PAINT ON THE FACER PLATE AND ACTUALLY REMOVE THE PAINT WHEN THE TAPE IS REMOVED. WE STRONGLY RECOMMEND THAT SCOTCH TAPE NOT BE USED ON PAINTED SURFACES NOR ANY OTHER TAPE THAT IS NOT ESPECIALLY DESIGNED FOR SUCH APPLICATIONS. MEDIUM OR LIGHT ADHESIVE MASKING OR MARKER LABEL TAPE IS RECOMMENDED IF TAPE IS USED. ANY TAPE LEFT ON PAINTED SURFACE FOR EXTENDED PERIODS WILL BE DIFFICULT TO REMOVE. NEVER BE CLEAR OR SCOTCH TAPE FOR THESE APPLICATIONS.

1. Read all safety and operating instructions before using this product.
2. All safety and operating instructions should be retained for future reference.
3. Obey all cautions in the operating instructions and on the back of the unit.
4. All operating instructions should be followed.
5. This product should not be used near water, i.e. a bathtub, sink, swimming pool, wet basement, etc.
6. This product should be located so that its position does not interfere with its proper ventilation. It should not be placed flat against a wall or placed in a built-in enclosure that will impede the flow of cooling air.
7. This product should not be placed near a source of heat such as a stove, radiator or another heat producing amplifier.
8. Connect only to a power supply of the type marked on the unit adjacent to the power supply cord.
9. Never break off the ground pin on the power supply cord. For more information on grounding write for our free booklet "Shock Hazard and Grounding".
10. Power supply cords should always be handled carefully. Never walk or place equipment on power supply cords. Periodically check cords for cuts or signs of stress, especially at the plug and the point where the cord exits the unit.
11. The power supply cord should be unplugged when the unit is to be unused for long periods of time.
12. If this product is to be mounted in an equipment rack, rear support should be provided.
13. Metal parts can be cleaned with a damp rag. The vinyl covering used on some units can be cleaned with a damp rag, or an ammonia based household cleaner if necessary.
14. Care should be taken so that objects do not fall and liquids are not spilled into the unit through the ventilation holes or any other openings.
15. This unit should be checked by a qualified service technician if:
  - A. The power supply cord or plug has been damaged.
  - B. Anything has fallen or been spilled into the unit.
  - C. The unit does not operate correctly.
  - D. The unit has been dropped or the enclosure damaged.
16. The user should not attempt to service this equipment. All service work should be done by a qualified service technician.



Features and specifications subject to change without notice.

A Division of Peavey Electronics Corporation

711 A Street, P. O. Box 2898, Meridian, MS 39302-2898 / (601) 483-5376 / Telex: 504115 / Fax: (601) 484-4278